

# CBCS SCHEME

USN

--	--	--	--	--	--	--	--	--	--

15AU52

## Fifth Semester B.E. Degree Examination, July/August 2021 Dynamics of Machines

Time: 3 hrs.

Max. Marks:80

Note: Answer any FIVE full questions.

- 1 a. Explain the following :
  - i) Two force member
  - ii) Three force member. (04 Marks)
- b. For the slider crank mechanism shown in below Fig.Q1(b), determine the input torque  $T$  on the link AB for static equilibrium.

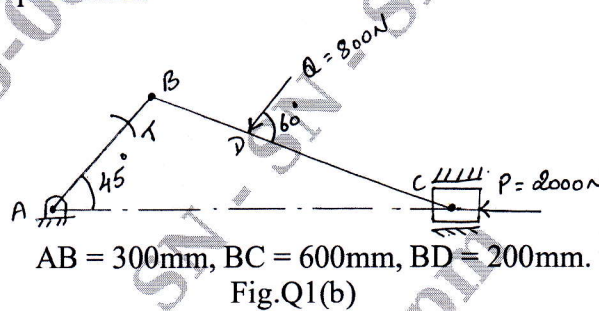

- 2 a. State and explain D'Alembert's principle. (04 Marks)
- b. Explain the dynamic forces analysis of four bar mechanism. (12 Marks)
- 3 a. What is static and dynamic balancing? Why balancing of rotating masses is necessary. (04 Marks)
- b. A rotating shaft carries four masses 1, 2, 3, and 4 which are radially attached to it. The mass centers are 30mm, 38mm, 40mm and 35mm respectively from the axis of rotation. The masses 1, 3 and 4 are 7.5, 5 and 4 kg respectively. The axial distance between the planes 1 and 2 is 400mm and 2 and 3 is 500mm. The masses 1 and 3 are at right angles to each other. Find for complete balance,
  - i) Angle between 1, 2 and 1, 4
  - ii) Axial distance between 3 and 4
  - iii) Magnitude of mass 2. (12 Marks)
- 4 The firing order in a 6 cylinder vertical 4 stroke in line engine is 1 - 4 - 2 - 6 - 3 - 5, the piston stroke is 100mm. Length of each C.R = 200mm. The pitch distance between cylinder centerlines are 100mm, 100mm, 150mm, 100mm and 100mm. Determine the out of balance primary and secondary forces and couples on this engine taking a plane midway between cylinders 3 and 4 as reference plane. The reciprocating mass per cylinder is 2 kg and the engine runs at 1500 rpm. (16 Marks)
- 5 a. Differentiate between flywheel and governor. (06 Marks)
- b. The flywheel of a steam engine has a radius of gyration of 1m and mass 2500kg. The starting torque of the steam engine is 1500Nm and may be assumed constant. Determine :
  - i) The angular acceleration of the flywheel
  - ii) The kinetic energy of the flywheel after 10 seconds from the start. (10 Marks)

Important Note : 1. On completing your answers, compulsorily draw diagonal cross lines on the remaining blank pages.  
2. Any revealing of identification, appeal to evaluator and /or equations written eg, 42+8 = 50, will be treated as malpractice.

- 6 a. Define the following :  
i) Sensitiveness  
ii) Hunting  
iii) Stability  
iv) Controlling force. (08 Marks)
- b. Each arm of a porter governor is 300mm long and is pivoted on the axis of the governor. Each ball has a mass of 6kg and the mass of sleeve is 18kg. The radius of rotation of ball is 200mm when the governor begins to lift and 250mm when the speed is maximum. Determine the maximum and minimum speed and the range of speed of governor. (08 Marks)
- 7 a. Discuss the laws of solid friction. (06 Marks)
- b. Derive an expression for total frictional torque of flat collar bearing considering uniform wear and uniform pressure. (10 Marks)
- 8 a. Derive an expression for ratio of belt tension. (08 Marks)
- b. In a flat belt drive the initial tension is 2000N. The coefficient of friction between the belt and the pulley is 0.3 and the angle of lap on the smaller pulley is  $150^\circ$ . The smaller pulley has a radius of 200mm and rotates at 500rpm. Find the power in kW transmitted by the belt. (08 Marks)
- 9 a. Derive an expression for gyroscopic couple considering a body rotating about axis. (06 Marks)
- b. Explain the gyroscopic effect on ships. (10 Marks)
- 10 a. Derive an expression for displacement, velocity and acceleration of follower when the roller is in contact with the nose in case of tangent cam with roller follower. (08 Marks)
- b. Derive an expression for displacement, velocity and acceleration of follower when the roller is in contact with straight flank in case of tangent cam with roller follower. (08 Marks)

\*\*\*\*\*